



*Product flyer*

Center hole grinding machine

**ZAMAG**



**ZSM-P-1000-SP150**

*with precision chuck  $\varnothing$ 150mm*



*swiss technology*

# One machine - Many advantages

## Highest precision:

The machine achieves a concentricity accuracy of 0.001mm

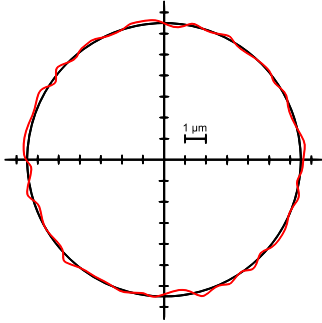

## You have the workpiece - We have the suitable machine:

Thanks to a lot of equipment possibilities the machine can be adapted exactly to your requirements and workpieces

## Swiss quality:

- Stable cast iron machine base (stress-free)
- Carriage with roller guides

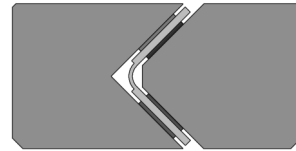

## Clamping of the workpieces in the chuck:

With the help of the three adjustable quills even workpieces with an inaccurate surface can be clamped and aligned

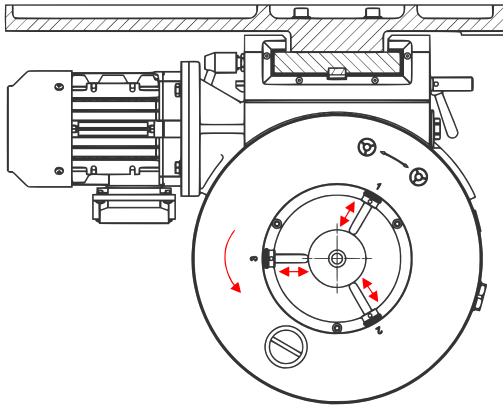

## Swivelling grinding head:

With the swivelling head the grinding angle can be adjusted between 0° and 90°

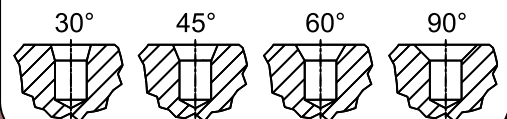

## With a lot of experience to the optimal result:

### Grinding principle:

1. rotary movement of the grinding wheel
2. stroke movement of the grinding wheel
3. rotating workpiece

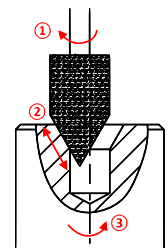

### Result:

A cross hatch pattern with oil pockets that provides optimum oil retention in the center holes

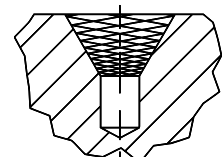

Mitracon GmbH

Bernstrasse 52

CH-4923 Wynau

+41 62 926 60 56

+41 62 926 60 59

office@mitracon-gmbh.ch

www.mitracon-gmbh.ch